

NITRATE LEACHING : SOME FUNDAMENTALS

K.C. Cameron

Department of Soil Science, Lincoln College, Canterbury

ABSTRACT

Leaching of nitrate frequently represents the greatest form of loss of nitrogen from the soil/plant system. Theoretical concepts of the movement of solutes through soil has enabled formulation of descriptive models of the leaching process. However, despite the resultant improvements in our knowledge regarding the factors controlling leaching, the use of terse mathematical descriptions of the leaching process has not resulted in universally accurate methods of predicting the nitrate loss. Empirical approaches to predicting nitrate leaching have been devised and to some extent they cater for the heterogeneous nature of soil and the complexity of the leaching process. These simulation models can also be adapted to incorporate soil N transformations.

A number of approaches to measuring nitrate leaching losses have been taken but all suffer from one limitation or another. Early work tended to be general and accurate measurements of the essential parameters affecting leaching were rarely made. More recently, studies have improved in design and precision of measurement and they go some way to enabling predictive models to be developed and tested. Data for New Zealand soils and climate is scant and work needs to be done here if a suitable method of predicting fertiliser N requirements is to include the essentials of the leaching process.

Additional Keywords: Nitrogen, solute movement, leaching theory, models, measurement, fertiliser, prediction.

INTRODUCTION

Leaching of nitrate (NO_3^-) is the major single loss in the nitrogen (N) budget for most soils and the essentials of this process should therefore be incorporated in methods for predicting crop fertiliser nitrogen requirements. The broad principles of solute leaching are understood but specific difficulties are met in quantifying the components of the system and yet maintaining simplicity of predictive methods.

The basic principles will be outlined in this paper and studies of leaching losses will be reviewed.

THEORY AND PREDICTION OF NITRATE LEACHING

An equation for the budget of nitrate in a defined area of soil at any one time may be written:

$$N_p + N_f + N_m = N_{pl} + N_g + N_i + N_l + N_r + \Delta N \quad (1)$$

where subscripts p = precipitation and irrigation, f = fertiliser and manure, m = mineralisation and fixation, pl = plant uptake, g = gaseous loss, i = immobilisation, l = leaching loss, r = runoff loss, and Δ = increase in soil. If the other parameters in the equation could be readily quantified, the leaching loss could be obtained simply by the difference. However, as this is not the case, the leaching process itself requires understanding to allow prediction.

Simple Convective Flow

It is convenient to consider first solute transport due to the mass flow of water alone (convection). Convective transport results from solutes being carried in soil water which is itself moving in response to a hydraulic gradient.

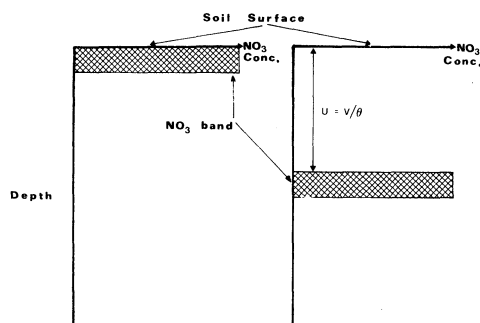

Figure 1: (a) Band of NO_3 applied to soil surface. (b) NO_3 band moved distance U by piston displacement resulting from V mm water applied to soil at moisture content θ .

The rate of water flow is dependent on the magnitude of the gradient and the hydraulic conductivity of the soil (Darcy's Law):

$$q = Q/A = -KdH/dx \quad (2)$$

where q = flux, Q = volume water, A = area, K = hydraulic conductivity, dH/dx = hydraulic gradient.

The convective flux of solutes carried (F_c) is simply their concentration in the water c times the water flux, therefore

$$F_c = qc = -c(KdH/dx) \quad (3)$$

Although soil pores vary greatly in size and tortuosity, we can compute an average apparent pore velocity U of the flowing solution:

$$U = q/\Theta \quad (4)$$

where Θ = soil volumetric water content.

When the rate of water applied to the soil V is less than the saturated hydraulic conductivity:

$$U = V/\Theta \quad (5)$$

For a free draining soil which is saturated when $\Theta = 0.5$ then $U = 2V$. In this situation, if a solution of nitrate was evenly applied to the surface of this soil at saturation and followed by an application of 25 mm of water, the band of nitrate would move 50 mm downwards (Fig. 1).

Unfortunately prediction of the rate of leaching is rather more complex than this. Firstly, because there is a very wide range of pore sizes in most soils the average value for the apparent pore velocity U includes pores flowing extremely fast and carrying solutes large distances and also small pores flowing extremely slowly only carrying solutes small distances. Secondly, the rate of flow of solute within an individual pore varies due to frictional drag on the surface of the pore (Fig. 2). Thirdly, the path length through a pore varies with the tortuosity of the pore. All of these factors lead to dispersion of solutes as they move through the soil and result in a general spread of the moving band of solute (Fig. 3).

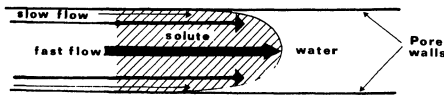

Figure 2: Flow velocity gradient within a pore.

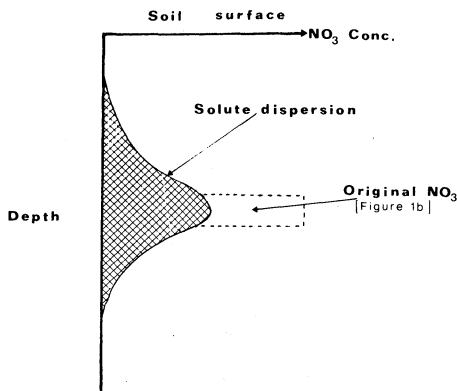

Figure 3: Hydrodynamic spread of nitrate band.

Furthermore, solutes are unlikely to be uniformly distributed within the soil solution. Concentration gradients cause solutes to move from areas of high concentration to those of low concentration and this molecular diffusion results in a flux which also spreads the originally uniform band as it moves through the soil.

Solute Convection and Dispersion Theory

The combined solute flux is thus complex and must take into account convective-dispersive-diffusive movement. The conventional equation used to describe this is usually given in the form:

$$\frac{\partial C}{\partial t} = D\left(\frac{\partial^2 C}{\partial x^2}\right) - U\frac{\partial C}{\partial x} \quad (6)$$

where D = dispersion coefficient.

Solutions of Equation 6 are given for various boundary conditions by Kirkham and Powers (1972). These types of equation have proved successful for the analyses of miscible displacement breakthrough curves from columns of uniform soil aggregates in the laboratory but, in general, tend to be of limited use in field situations. The major difficulty is in obtaining an appropriate value for the dispersion coefficient D . Accurate values can be computed from data for laboratory column experiments but values for soils in the field are more variable and must be measured in an involved field leaching experiment. Using an appropriate field value, a recent deterministic model based essentially on Equations (5) and (6) (Rose *et al.*, 1982 a, b) has nevertheless been shown to be applicable under a range of leaching conditions (Cameron and Wild, 1982).

Nitrate adsorption occurs in some soils due to the presence of certain types of clay, iron and aluminium oxides and hydroxides and allophane. When adsorption occurs it retards the rate of nitrate leaching (Black and Waring, 1976) and has previously been accounted for by modification of leaching equations to include a retardation factor (Davidson and Chang, 1972).

Further complications arise due to biological N transformations and their inclusion even as simple source/sink terms lead to equations which become very difficult to solve analytically and numerical techniques are required (Bresler, 1973).

Empiricism

Empirical methods have been developed which model water flow and solute transport on the basis of some relatively simple concepts and easily measurable soil parameters (Burns, 1974; Addiscott, 1977). Essentially, the soil profile is considered as a series of layers which have parameters controlling the rate of water and solute movement through each layer to the one below (Fig. 4). The repetitive nature of these multicompartment simulation models usually requires a simple computer programme. For example, in the Burns (1974) model, each layer has its own characteristic value of moisture content at field capacity and specified initial water and nitrate contents. When rainfall exceeds evaporation the net water excess is added to the top layer and is simulated to move down the profile if the input causes the water content to exceed field capacity. As water moves into each successive layer it is assumed to equilibrate with the nitrate present and thus invoke solute transfer from one layer to another. Although shown to account successfully for nitrate leaching in some sandy soils (Burns, 1975), the model fails on coarsely structured soils (Cameron and Wild, 1982).

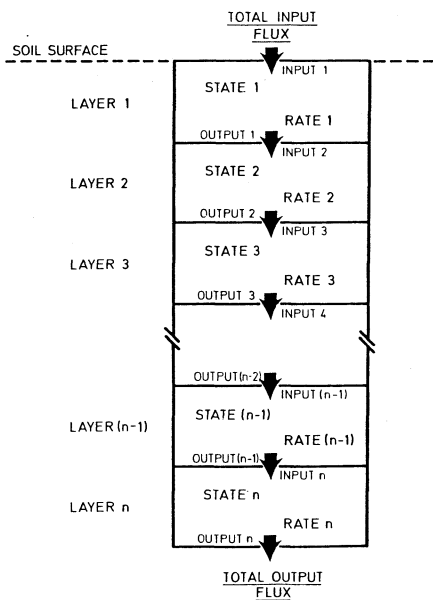

Figure 4: Multicompartiment simulation model.

A similar model (Addiscott, 1977) caters for more coarsely structured soils by partitioning the soil water into mobile and immobile phases. Although the physical basis is better, the model parameters are more difficult to define.

There are a number of advantages to multicompartiment simulation models. Layered soils may be studied, and it is not necessary to assume steady state nor saturated conditions. Also, model parameters may easily be altered and can usually be derived from simple experiments. Soil nitrogen transformation processes may also be added to the original model.

Sophisticated computer simulation models of the N-cycle have been developed overseas (for review see Tanji and Gupta, 1978) and attempts have been made to construct conceptual models of the complete N-cycle for some New Zealand soils (Steel, 1982). Although testing such models is warranted it is not currently possible because the parameters in Equation 1 cannot be derived independently and the measurements required are lacking.

MEASUREMENTS OF NITRATE LEACHING

Nitrate leaching losses can be measured in a number of ways. I will consider field sampling and borehole studies, tile drain and catchment studies, and lysimeter studies.

Field Sampling and Boreholes

The profile distribution of nitrate can be measured by soil sampling and extraction of the soil with a salt solution (Bremner, 1965). Alternatively, porous ceramic cups can be used to extract the soil solution (Hansen and Harris, 1975).

These data, when combined with measurements of the water flux, allows calculation of the loss in kg N/ha. The major constraints are that large numbers of measurements are required to be representative of an area and that deep samples may be difficult to obtain from stony soils. With porous cups, there is uncertainty about the nature of the soil solution being extracted.

Studies by these methods have successfully shown that large winter leaching losses of nitrate occur following autumn ploughing of grassland (170 kg N/ha, Ludecke and Tham, 1971; > 100 kg N/ha, Cameron and Wild, 1983) and that cropped soils can contribute to the nitrate load of underlying aquifers (Adams *et al.*, 1979).

It is generally accepted that leaching losses from pasture are small because of the ability of grass to assimilate large amounts of nitrogen. However, intensively stocked pastures may be an exception because substantial leaching losses are thought to occur from urine patches (Walker, 1956; O'Connor, 1974). Leaching losses of over 50 kg N/ha have been reported from unfertilised grass and losses of 200 kg N/ha from grass receiving 450 kg N/ha/yr of fertiliser (Ball, 1979).

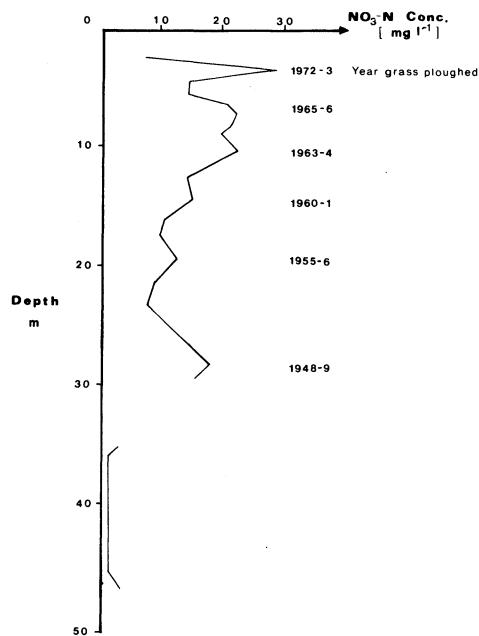

Figure 5: Nitrate distribution profile in Chalk (dates relate to years when grass was ploughed up).

In agricultural studies, movement of nitrate below a depth of 1 or 2 m is rarely monitored but, insofar as it affects the quality of drinking water in aquifers, it is also important. Deep borehole samples taken in Chalk in England showed a relationship between the concentration

of nitrate in the interstitial water and land use history (Young *et al.*, 1976; Young and Gray, 1978). The highest concentrations were found beneath fertilised arable land (15-50 mg N/l or higher) and the lowest were beneath unfertilised permanent grassland (2-20 mg N/l). High concentrations were also related to the ploughing up of well established grass (Fig. 5). In New Zealand, boreholes drilled in the Ngatarawa Valley, Hawkes Bay (Burden, 1980) showed high concentrations of nitrate moving from pasture soils into the groundwater ($>10 \mu\text{g/g}$). Leaching losses of nitrogen were estimated to be 20 kg N/ha/yr from dryland and 66 kg N/ha/yr from irrigated pasture. These values are similar to the estimates for Mid-Canterbury pastures given by Quin (1979).

Tile Drain Effluent and Catchment Studies

Although useful comparative data have resulted from intermittent sampling of tile drain effluents, unless there is truly proportional water sampling, the concentrations of effluents are often not reliable indicators of field leaching losses (Cooke and Williams, 1970; Thomas and Barfield, 1974). A further problem is the uncertainty of whether the water collected by the tile is representative of the total drainage.

The extensive body of literature reports variable relationships between amount of N applied and the amount and concentration in effluent. This is probably because of the variety of soils, crops, fertilisers, climate and drainage designs. Reviews and summaries have been given by Wadleigh (1968), Tennessee Valley Authority (1969), Winteringham (1976, 1977) and Wild and Cameron (1980).

Drainage water samples from under continuous winter wheat at Rothamsted (Cooke, 1976) showed greater loss of nitrate from autumn applications of ammonium salts than from spring applications. Substantial losses of nitrate from application of farmyard manure were found and there was a greater loss of nitrate from spring applications of nitrate fertiliser than from ammonium salts at the same time.

Analyses of drainage water reported by Williams (1976) shows mean nitrate concentrations to be higher from arable land (22 mg NO_3^- -N/l) than from grass/lucerne pastures (4 mg NO_3^- -N/l).

On defined areas with an impermeable sub-stratum when most of the drainage water can be monitored and sampled, this is considered as a catchment study. In large catchments there are usually errors in measuring inputs and outputs, especially where the intensity of management varies within the catchment. Reviews and summaries have been given by Atkins (1968), Viets and Hageman (1971), Kolenbrander (1972), and Winteringham (1976, 1977).

Hood (1976a, b) reported one of the few catchment area studies in which drainage volumes were continuously recorded and proportionally sampled (Table 1). Two separate grass areas within a 10 ha site received either a high-N application (750 kg N/ha/yr) or a low-N application (250 kg N/ha/yr). Over the first four years of the study, an average of 7% of applied N to the low-N and 11% of the applied N to the high-N was lost in the drainage. The greatest amounts of nitrate were leached during the winter

TABLE 1: Annual balance sheet for grassland. Mean data kg N/ha for 4 years (1971/2 - 1974/5) (Hood 1976a).

	Low N (250 kg N/ha/yr)	High N (750 kg N/ha/yr)
Inputs		
Fertiliser	250	750
Recycled from supplementary feed	23*	26*
Recycled from grazed grass	94*	148*
Rain	10	10
	377	934
Outputs		
Grazed grass	167	254
Silage	72	106
Field drainage	11	54
Leached below drains	10*	31*
	260	445
Balance	+ 117	+ 489

* = estimates

period. Rainfall in the current and preceding year was shown to affect nitrate losses.

In New Zealand, Sharpley and Syers (1981) reported amounts of N lost and its relationship to water flow from a 20 ha pasture catchment near Palmerston North. The area was intermittently grazed by cattle. Urea (60 kg N/ha) was applied to a 14 ha subcatchment each year. The pattern of rainfall affected the nitrate concentration and after periods of no leaching, higher values were observed, possibly due to the accumulation of mineralised nitrogen. Table 2 gives the average losses for the 3 year study period.

TABLE 2: Average (3 yrs) discharge (kg N/ha/yr), NO_3^- -N, particulate N (Kjeldahl digest) and total N (sum previous) in surface, accelerated subsurface (tiles) and stream flow from field measurements and in subsurface runoff from hydrograph analysis (Sharpley and Syers, 1981).

	Surface runoff	Accelerated subsurface runoff	Subsurface runoff	Stream flow
Discharge (m^3 /ha/yr)	1910	1570	2530	3950
NO_3^- -N	0.5	9.4	11.6	16.8
Particulate N	5.6	3.3	2.8	6.3
Total N	6.1	12.7	14.4	23.4

TABLE 3: Summary of data from selected lysimeter experiments (from Atkins, 1976, with additions).

Location & Soil	Period	Crop	N fert. rate kg/ha/yr	N in drainage kg/ha/yr
Hurley (UK) ¹ (sandy loam)	4 years (1970-74)	grass	250	6
			500	128
Limburgerhof (W. Germany) ² (sandy soil)	6 years	winter rye	0	61
			80	74
	6 years	oats	0	59
			80	60
6 years	potatoes	0	43	
		80	47	
Gleadthorpe (UK) ³ (loamy sand)	3 years (1971-74)	barley	0	54
			113	61
Groningen (Netherlands) ⁴ (sandy soil)	10 years (1958-68)	grass	8 x 30	13
Groningen (Netherlands) (clay soil)	7 years (1961-68)	grass	3 x 50	5

References

1. Garwood and Tyson (1977).
2. Pfaff (1963).
3. Skinner (1971, 72, 73); Dampney and Prince (1974).
4. Kolenbrander (1969).

Lysimeter Studies

Lysimeters allow quantitative measurements from a defined soil volume but, although they avoid the large variations associated with field studies, they do suffer from container edge effects leading to increased aeration and preferential drainage pathways. Furthermore, most types are isolated from the effects of the subsoil. A suction lysimeter system installed in the field (Cole *et al.*, 1961; Goh *et al.*, 1979) avoids some of these problems but no longer confines the soil volume being studied.

Results from the early lysimeter studies are of limited value due to their poor design and inappropriate management. Results and environmental factors are still often reported incompletely and it has been recommended that information should be reported on amount and intensity of rainfall, evapotranspiration, drainage volume, concentration and amount of nitrogen in the drainage, form and amount of N fertiliser, crop uptake, previous cropping and soil properties including total N (Wild and Cameron, 1980). An improved lysimeter designed by Belford (1979) should allow more reliable monitoring.

A selection of results from lysimeter studies are given in Table 3. Differences in lysimeter design, management, soil and climate make generalisations from reported data difficult, however, from 57 lysimeter trials reported by Atkins (1976) and others, the following statements can be made:

- (a) The land use system is of primary importance, the ratio of amounts of N leached under grass (not grazed), cereals and bare fallow being 1.6:3.0.

- (b) From a fertiliser application of 100 kg N/ha, the leaching loss is about 0.2 kg N/ha under grass (not grazed), 2-12 kg N/ha under arable and 60-80 kg N/ha under fallow.
- (c) Leaching loss increases with the size of the fertiliser application but the effect of the cropping system remains important.
- (d) Slightly greater leaching occurs from nitrate fertiliser than from ammonium fertiliser.
- (e) Greatest leaching losses occur during winter in proportion to the amount of rainfall.
- (f) Dry years result in accumulations of soil N and subsequent winter rain can result in large losses.
- (g) Optimum water supplies during summer can improve crop yield (N uptake) and reduce the leaching loss.
- (h) Leaching losses are greater from sandy soils than clay soils.
- (i) Soil pH has little effect on leaching but some increased losses have been reported at higher pH values.

CONCLUSIONS

The assessment of fertiliser nitrogen requirements can only be made if at least the basic principles of soil N processes are considered. Leaching is the major source of nitrogen loss from the soil/plant system and quantitative description is essential even though it is complex. Leaching losses have been monitored by various methods and much data is reported in the literature. However, critical appraisal shows that reliable quantitative data is scarce.

Losses vary according to the cropping system, fertiliser application, soil physical properties and both the amount and intensity of rainfall, therefore further research into their interactive effects is needed before nitrate leaching or N fertiliser recommendations can be reliably estimated.

REFERENCES

- Adams, J.A., Campbell, A.S., McKeegan, W.A., McPherson, R.J., Tonkin, P.J. 1979. Nitrate and chloride in groundwater, surface water, and deep soil profiles of Central Canterbury, N.Z. *Progress in Water Technology* 11: 351-360.
- Addiscott, T.M. 1977. A simple computer model for leaching in structured soils. *Journal of Soil Science* 28: 554-563.
- Atkins, S.F. 1968. "Nitrates in Natural Waters (mainly England): Literature Review". Imperial Chemical Company Research Department report TMJ 266 (unpublished).
- Atkins, S.F. 1976. "Nitrogen Leaching from Fertilisers: Lysimeter Trials: Published Results from Europe and U.S.A.". Imperial Chemical Company Research and Development Department (unpublished).
- Ball, P.R. 1979. Nitrogen relationships in grazed and cut grass clover systems. Ph.D. Thesis, Massey University, New Zealand: 217 p.
- Belford, R.K. 1979. Collection and evaluation of large soil monoliths for soil and crop studies. *Journal of Soil Science* 30: 363-373.
- Black, A.S., Waring, S.A. 1976. Nitrate leaching and adsorption in a krasnozem from Redland Bay, Qld. III: Effect of nitrate concentration on adsorption and movement in soil columns. *Australian Journal of Soil Research* 14: 189-195.
- Bremner, J.M. 1965. Inorganic forms of nitrogen. In "Methods of Soil Analysis". Part 2. Ed. C.A. Black. American Society of Agronomy, Wisconsin.
- Bresler, E. 1973. Simultaneous transport of solutes and water under transient unsaturated flow conditions. *Water Resources Research* 9: 975-986.
- Burden, R.J. 1980. Distribution of nitrate-N concentrations in groundwater beneath intensively grazed pastureland in the Ngatarawa Valley, Hawke's Bay. *Journal of Hydrology (N.Z.)* 19: 94-105.
- Burns, I.G. 1974. A model for predicting the redistribution of salts applied to fallow soils after excess rainfall or evaporation. *Journal of Soil Science* 25: 165-178.
- Burns, I.G. 1975. An equation to predict the leaching of surface-applied nitrate. *Journal of Agricultural Science, Cambridge* 85: 443-454.
- Cameron, K.C., Wild, A. 1982. Prediction of solute leaching under field conditions: an appraisal of three methods. *Journal of Soil Science* 33: 659-669.
- Cameron, K.C., Wild, A. 1983. Potential aquifer pollution from nitrate leaching following the plowing of temporary grassland. *Journal of Environmental Quality* (in press).
- Cole, D.W., Gessel, S.P., Held, E.E. 1961. Tension lysimeter studies of ion and moisture movement in glacial till and coral atoll soils. *Proceedings Soil Science Society of America* 25: 321-324.
- Cooke, G.W. 1976. A review of the effects of agriculture on the chemical composition and quality of surface and underground waters. In "Agriculture and Water Quality" Ministry of Agriculture and Fisheries, Technical Bulletin 32: HMSO, London. pp. 5-57.
- Cooke, G.W., Williams, R.J.B. 1970. Losses of nitrogen and phosphorus from agricultural land. *Water Treatment and Examination* 19: 253-276.
- Dampney, P.R.M., Prince, J. 1974. Fertiliser losses due to leaching (lysimeter experiment) (3 AC 48) ADAS E. Midland Region Reports of Field Experiments. pp. 149-152 (unpublished).
- Davidson, J.M., Chang, R.K. 1972. Transport of picloram in relation to soil physical conditions and pore water velocity. *Proceedings Soil Science Society of America* 36: 257-261.
- Garwood, E.A., Tyson, K.C. 1977. High loss of nitrogen in drainage from soil under grass following a prolonged period of low rainfall. *Journal of Agricultural Science, Cambridge* 89: 767-768.
- Goh, K.M., Edmeades, D.C., Hart, P.B.S. 1979. Direct field measurements of leaching losses of nitrogen in pasture and cropping soils using tension lysimeters. *N.Z. Journal of Agricultural Research* 22: 133-142.
- Hansen, E.A., Harris, A.R. 1975. Validity of soil-water samples collected with porous ceramic cups. *Proceedings Soil Science Society of America* 39: 528-536.
- Hood, A.E.M. 1976a. Leaching of nitrates from intensively managed grassland at Jealotts Hill. In "Agriculture and Water Quality" Ministry of Agriculture, Food and Fisheries Technical Bulletin 32: HMSO, London. pp 201-222.
- Hood, A.E.M. 1976b. Nitrogen, grassland and water quality in the United Kingdom. *Outlook on Agriculture* 8: 320-327.
- Kirkham, D., Powers, W.L. 1972. "Advanced Soil Physics". Wiley Interscience, New York.
- Kolenbrander, G.J. 1969. Nitrate content and nitrogen loss in drain water. *Netherlands Journal of Agricultural Science* 17: 246-255.
- Kolenbrander, G.J. 1972. Technical report. In "Report on the Working Group on Fertilisers and Agricultural Waste Products". Organisation for Economic Co-operation and Development. NR/ENV/72.25, Paris.
- Ludecke, T.E., Tham, K.C. 1971. Seasonal variations in the levels of mineral nitrogen in two soils under different management systems. *Proceedings Agronomy Society of N.Z.* 1: 203-214.
- O'Connor, K.F. 1974. Nitrogen in agrobiosystems and its environmental significance. *N.Z. Agricultural Science* 8: 137-148.

- Pfaff, C. 1963. Das Verhalten des Stickstoffs im Boden nach langjährigen. Lysimeterversuchen. 1. Mitteilung. *Z. Acker-U PflBau* 117: 77-99.
- Quin, B.F. 1979. The effects of surface irrigation on drainage and groundwater quality. In "The Quality and Movement of Groundwater in Alluvial Aquifers of New Zealand". Ed. M.J. Noonan, Lincoln College, Canterbury. pp. 139-145
- Rose, C.W., Chichester, F.W., Williams, J.R., Ritchie, J.T. 1982a. A contribution to simplified models of field solute transport. *Journal of Environmental Quality* 11: 146-150.
- Rose, C.W., Chichester, F.W., Williams, J.R., Ritchie, J.T. 1982b. Application of an approximate analytic method of computing solute profiles with dispersion in soils. *Journal of Environmental Quality* 11: 151-155.
- Sharpley, A.N., Syers, J.K. 1981. Amounts and relative significance of runoff types in the transport of nitrogen into a stream draining an agricultural watershed. *Water, Air and Soil Pollution* 15: 299-308.
- Skinner, R.J. 1971. Fertiliser losses due to leaching (lysimeter experiment) (3AC 48) ADAS E. Midland Region Reports of Field Experiments pp. 149-152. (unpublished).
- Skinner, R.J. 1972. Fertiliser losses due to leaching (lysimeter experiment) (3AC 48) *Ibid.* 171-174.
- Skinner, R.J. 1973. Fertiliser losses due to leaching (lysimeter experiment) (3AC 48) *Ibid.* 161-163.
- Steele, K.W. 1982. Nitrogen in grassland soils. In "Nitrogen Fertilisers in New Zealand Agriculture". Ed. P.B. Lynch. New Zealand Institute of Agricultural Science, Wellington. pp. 29-45.
- Tanji, K.K., Gupta, S.K. 1978. Computer simulation modelling for nitrogen in irrigated croplands. In "Nitrogen in the Environment". Vol. 1. Ed. D.R. Nielsen, J.G. MacDonald, Academic Press, New York.
- Tennessee Valley Authority 1969. "Effects of Fertilisers on Water Quality: a collection of abstracts".
- Thomas, G.W., Barfield, B.J. 1974. The unreliability of tile effluent for monitoring subsurface nitrate-nitrogen losses from soils. *Journal of Environmental Quality* 3: 183-185.
- Viets, F.G.Jr., Hageman, R.H. 1971. "Factors Affecting the Accumulation of Nitrate in Soil, Water and Plants". Agriculture Handbook Number 413, U.S. Department of Agriculture, Washington D.C.
- Wadleigh, C.H. 1968. "Wastes in Relation to Agriculture and Forestry". Miscellaneous Publication of U.S. Department of Agriculture Number 1065.
- Walker, T.W. 1956. The nitrogen cycle in grassland. *Journal of the Science of Food and Agriculture* 7: 66-72.
- Wild, A., Cameron, K.C. 1980. Soil nitrogen and nitrate leaching. In "Soils and Agriculture" Ed. P.B. Tinker. Critical Reports in Applied Chemistry, Volume 2; Society of Chemical Industry, Blackwell, Oxford. pp. 35-70.
- Williams, R.J.B. 1976. The chemical composition of rain, land, drainage and borehole water from Rothamsted, Saxmundham, and Woburn experimental stations. In "Agriculture and Water Quality" Ministry of Agriculture, Food and Fisheries Technical Bulletin 32: HMSO, London. pp. 174-200.
- Winterringham, F.P.W. 1976. Nitrogen balance studies with particular reference to nitrogen sources; and mineral nitrogen levels and trends as a function of agricultural practices. International Atomic Energy Authority working paper (unpublished).
- Winterringham, F.P.W. 1977. Nitrogen balance and related studies. International Atomic Energy Authority working paper (unpublished).
- Young, C.P., Hall, E.S., Oakes, D.B. 1976. "Nitrate in Groundwater Studies on the Chalk near Winchester, Hampshire". Water Research Centre Technical Report 31.
- Young, C.P., Gray, E.A. 1978. "Nitrate in Groundwater". Water Research Centre Technical Report 69.